

SYNOPSIS OF PROJECT REPORT

TITLE

**“GREEN MICRO GRIDS:
A PATH TO SMARTER RENEWABLE ENERGY USE”**

PROJECT ID : NSF-SCH-2025-21

NAME : MOHAMMED SAALIH .O.M

SCHOOL : USWATHUN HASANA ISLAMIC INTERNATIONAL SCHOOL

CITY & STATE : PALLAPATTI, KARUR, TAMILNADU

**“GREEN MICRO GRIDS:
A PATH TO SMARTER RENEWABLE ENERGY USE”**

-MOHAMMED SAALIH .O.M

Abstract:

- Green micro grids are small, localized power systems that integrate renewable energy sources like solar and wind with storage units to provide reliable and eco-friendly electricity.
- They reduce dependence on fossil fuels, cut transmission losses, and optimize renewable energy usage.
- This project focuses on how green micro grids can improve energy efficiency, support rural electrification, and promote sustainability.
- This project explores the concept of green microgrids and their role in promoting smarter renewable energy usage.
- Microgrids help integrate renewable sources like solar and wind efficiently, ensuring continuous energy supply with reduced carbon footprint.

Introduction:

- A **micro grid** is a small-scale electricity network that can operate on its own (independent) or connected to the main power grid.
- A **green micro grid** uses renewable energy sources like solar panels and wind turbines instead of fossil fuels.
- They help save energy, reduce pollution, and provide power even when the main grid fails.

Renewable Energy:

- Renewable energy comes from natural sources such as sunlight, wind, water, and biomass. Globally, renewable energy contributes about 30% to total electricity generation (IEA, 2024).
- It plays a vital role in reducing greenhouse gas emissions and ensuring sustainable development.

a. Selection of Problems & Background Information

• Problems Identified:

- Dependence on fossil fuels.
- Power outages and transmission losses.
- Inefficiency in using renewable energy due to intermittency.

• Background:

- According to IEA, nearly **20% of global electricity** comes from renewable sources, but integration into main grids is inefficient.
- Micro grids provide decentralized power management, reduce carbon footprint, and support rural electrification.

- Countries like India and the USA are piloting community-based green micro grids.

b. Research Question:

“How can green microgrids improve the usage of renewable energy and make electricity more reliable and eco-friendly?”

c. Hypothesis:

- If renewable energy sources are connected through a green microgrid with energy storage (batteries), then energy usage will be more efficient and reliable compared to using a single renewable source directly.

Objectives:

- To design a model of a green micro grid with renewable energy inputs.
- To study how energy storage and demand-response systems optimize energy usage.
- To analyze environmental and economic benefits of microgrids.
- To propose a scalable model for rural and urban communities.
- To test how combining sources (solar + battery or solar + wind) improves energy supply.

What Are Green Microgrids?

- **Microgrid:** A small-scale power grid that can operate independently or with the main grid.
- **Green Microgrid:** Uses renewable energy sources like solar, wind, and biomass to generate electricity.

Why Are They Important?

- Reduce pollution and greenhouse gases.
- Provide reliable electricity in remote or disaster-prone areas.
- Help transition from fossil fuels to clean energy.

Key Components:

- **Renewable Energy Sources:** Solar panels, wind turbines, hydroelectric systems.
- **Energy Storage:** Batteries store excess energy for use when sun or wind isn't available.

Smart Controllers: Manage energy flow and balance supply with demand.

Concept of Green Microgrids:

- Green microgrids combine renewable energy technologies, smart meters, and energy storage systems to optimize power usage. They reduce dependence on fossil fuels and promote sustainability.

Working Principle and Components:

- A green microgrid consists of renewable sources (solar panels, wind turbines), energy storage (batteries), a control unit, and the load (users). The control system balances energy generation and demand efficiently.

Materials Needed:

- Small **solar panel** (mini panel ~5–6V)
- Small **DC motor with fan blades** (to act as a wind turbine)
- **Rechargeable battery** (3.7V Li-ion or AA batteries with holder)
- **LED bulbs** (to represent electricity usage)
- **Switches** and connecting wires
- **Breadboard** or cardboard base for mounting
- Multimeter

Circuit connection:

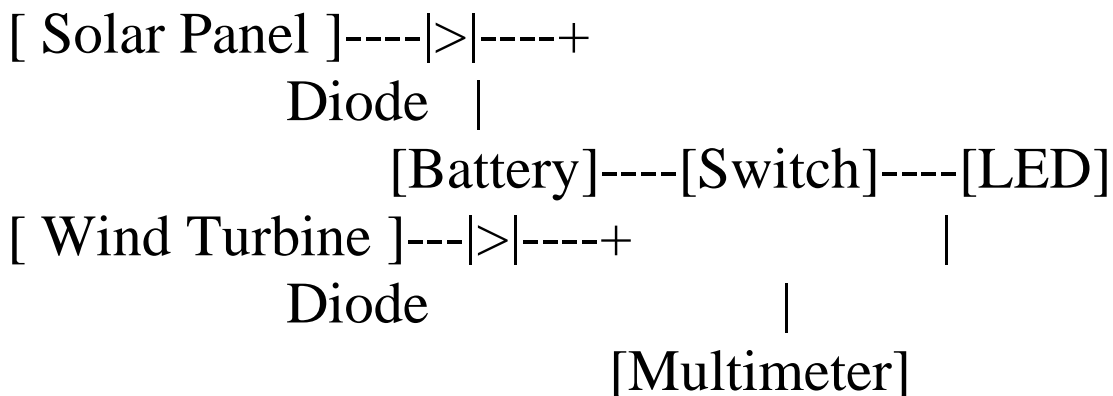

Example for renewable energy micro grid:

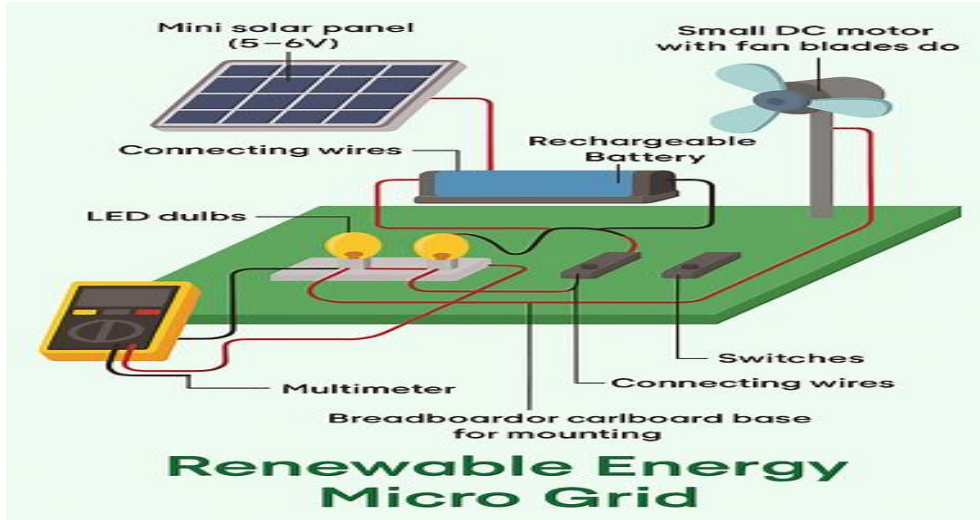

d. Procedure:

1. Collect data on solar and wind availability in the chosen area.
2. Set up small-scale renewable energy sources (solar panels, wind turbine).
3. Connect to a microgrid with battery storage and inverter.
4. Use microcontroller to monitor input, output, and load demand.
5. Simulate various conditions (sunny day, cloudy day, windy, no wind).
6. Record energy generated, stored, and consumed.

Circuit Schematic (text diagram)

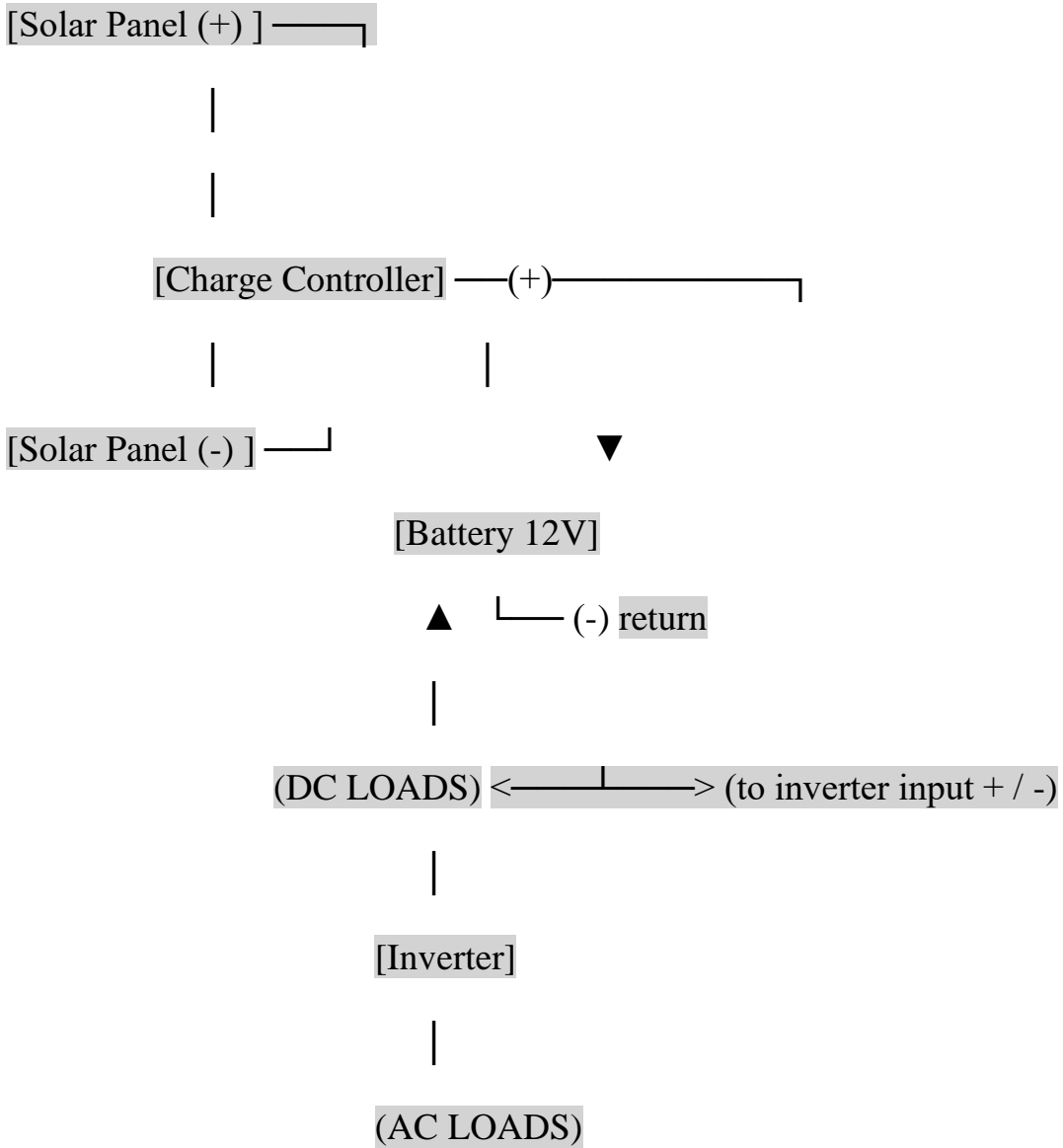

Add protective devices:

- Put a **fuse** between the charge controller and battery positive (+).
- Place a **fuse** between battery positive and inverter positive.
- Use a **switch/relay** between inverter output and AC loads to simulate grid-connect/disconnect.

Methodology:

1. **Model solar supply:** Connect solar panel → LED bulb → measure brightness (or voltage).
2. **Model wind supply:** Connect mini wind turbine → LED → test output when fan/wind is applied.
3. **Add storage (battery):** Store energy in a rechargeable battery using solar panel during the day. Use battery to power LED at night.
4. **Combine into microgrid:** Connect solar + wind + battery in parallel, then supply LED load. Add a simple switch to simulate automatic shifting of sources.

Wiring & Connection Steps:

1. **Mount components** on a wooden board or stable base. Secure solar panel on a small stand at an angle toward light.
2. **Battery negative (-)** → connect to the common negative bus (black wires).
3. **Solar panel + to charge controller +**, and solar panel - to charge controller -. Tighten terminals.

4. **Charge controller + output** → through a **10 A fuse** → to **battery +**. Connect charge controller negative to battery negative.
5. **Battery +** → through a **10–15 A fuse / switch** → to **inverter +**. Connect battery negative to inverter negative.
6. **Inverter AC output** → to AC load (e.g., small bulb). Use a switch on AC side to turn load on/off.
7. **Install meters**: place voltmeter across battery terminals; ammeter in series with DC load or between battery + and load. If using a multimeter, follow the meter's wiring instructions.
8. **Controller / relay** (optional): wire a relay to switch the inverter output or to disconnect the solar input to simulate islanding or grid failure. Use the relay coil to be controlled manually or by a simple Arduino/logic if available.
9. **Check connections**: ensure all connections are tight, correct polarity, and fuses are in place before switching on. No bare wires should be exposed.

Recommended Wire Sizes & Protection:

- For small demo (≤ 15 A at 12 V): use **2.5 mm²** (approx. 14–16 AWG) for battery/inverter positive and negative.
- Use **insulated terminals**, proper **ring lugs**, and **inline fuses** near the battery + terminal.
- Always place the fuse as close to the battery positive as possible.

Measurements & Data Logging:

Create a table like this and fill during experiment:

Time	Solar V (V)	Solar I (A)	Battery V (V)	Load I (A)	Load V (V)	Load Power (W)
10:00	18.5	1.2	12.5	0.8	12.4	9.9
10:10

Calculate:

- Solar power \approx Solar V \times Solar I.
- Load power \approx Load V \times Load I.
- Efficiency estimate = (Energy delivered to load) / (Energy from solar) \times 100%.

5. Observation:

- Note when solar works (daylight), wind works (fan blowing), and battery supports load.
- Compare single-source supply (only solar, only wind) vs. combined microgrid system.

e. Comparison table of Traditional Grid vs. Green Micro grid

Property	Traditional Grid	Green Micro grid
1. Energy Source	Fossil fuels mainly	Solar, wind, biomass
2. Transmission Loss	High	Very low
3. Reliability	Dependent on main grid	Independent, localized
4. Environmental Impact	High emissions	Low emissions
5. Cost Efficiency	Moderate	High (after setup)

Comparison: Traditional Grid vs Microgrid:

Traditional grids rely heavily on centralized fossil fuel plants, while microgrids use decentralized renewable systems. Below is a comparison of average global energy loss:

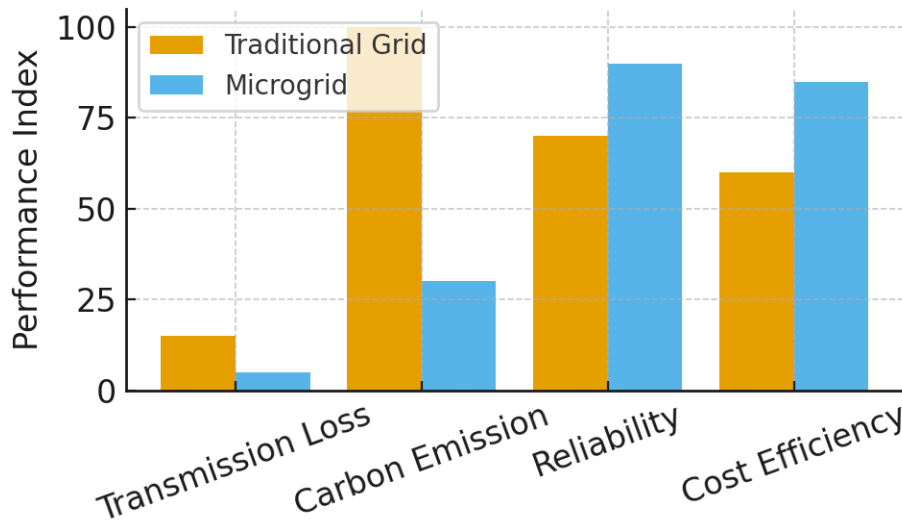

Comparison between Traditional Grid and Microgrid.

Pie Chart –Energy Contribution in Micro grid

Renewable energy mix in micro grids:

- **Solar Energy – 50%**
- **Wind Energy – 30%**
- **Battery Storage – 15%**
- **Other (biomass/hydro) – 5%**

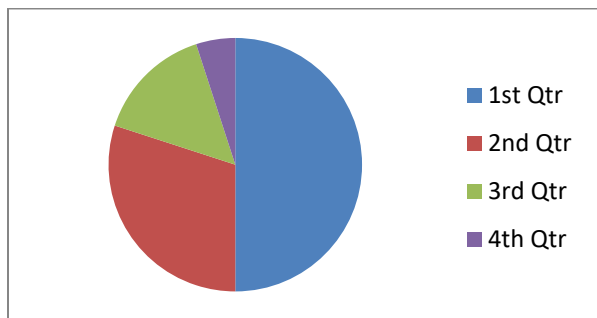

f. Data Collection:

Table of **Voltage/Current** from solar panel under sunlight and under lamp.

- LED brightness or number of LEDs supported by:
 - Solar only
 - Wind only
 - Battery only
 - Combined micro grid
- Record how long the LED stays ON with each setup.

Global Data: Energy Efficiency & Cost Reduction:

According to the International Renewable Energy Agency (IRENA, 2024), microgrids improve energy efficiency by approximately 25–30% and reduce operational costs by up to 20%. Table below shows sample data of microgrid impact across different regions.

Region	Energy Efficiency Improvement (%)	Cost Reduction (%)
North America	28	18
Europe	30	20
Asia-Pacific	26	17
Africa	22	15

Risk and Safety:

- Electrical short circuits (use insulated wiring and fuses).
- Battery handling risks (avoid overcharging, use protective casing).
- Weather conditions affecting solar/wind systems.
- Safety gear (gloves, goggles) required while handling electrical connections

Primary Function:

To optimize renewable energy usage through a

- Localized
- Sustainable
- efficient green micro grid system that reduces fossil fuel dependence
- Supports clean energy transition.

Advantages of Green Microgrids:

1. Lower carbon emissions
2. Improved energy efficiency
3. Reliable power supply
4. Reduced transmission losses
5. Integration of renewable sources

Challenges in Implementation

1. High initial investment
2. Complex management systems
3. Lack of skilled workforce
4. Need for advanced battery storage technologies

Future Outlook:

- Integration with smart cities.
- More affordable battery technologies.
- AI-powered energy forecasting.

Expecting Results:

- Green micro grid will show **higher efficiency and reliability** compared to a traditional grid.
- Reduction in **carbon footprint** and **energy wastage**.
- Practical demonstration of renewable integration for schools, villages, and smart cities.
- Promotion of **sustainable and decentralized energy solutions**.

g. BIBLIOGRAPHY:

1. Katiraei, F., & Iravani, M. R. (2006). *Power management strategies for a microgrid with multiple distributed generation units*. IEEE Transactions on Power Systems, 21(4), 1821–1831.
2. Liu, W., Gu, W., Wu, Z., & Zhou, J. (2019). *Energy management of community microgrids considering renewable energy utilization*. Applied Energy, 235, 95–104.
3. International Renewable Energy Agency (IRENA). (2019). *Innovation Outlook: Renewable Mini-grids*.
4. U.S. Department of Energy (DOE). (2020). *The Role of Microgrids in Helping to Advance the Nation's Energy System*
5. Hatziargyriou, N. (2014). *Microgrids: Architectures and Control*. Wiley-IEEE Press.